

Pressure Sensitive Adhesives and Their Use in the Building Enclosure

Cody Shelner, P.E.

AIA
Continuing
Education
Provider



Pressure Sensitive Adhesives and Their Use in the Building Enclosure

Pressure sensitive adhesives (PSAs) are essential for high-performing, energy-efficient air barrier systems in building enclosures. This session will overview the main PSA types highlighting their properties, substrate compatibility, and environmental durability.

The presentation will cover how PSAs maintain airtight seals in self-adhered membranes, tapes, interfaces, and critical details, streamlining installation and enhancing air leakage control.



Cody Shelner, P.E.

Cody Shelner is a leading expert in pressure sensitive adhesives and self-adhered membrane technologies, recognized for his innovative contributions to the construction materials industry. His technical background and problem-solving skills have enabled him to collaborate with manufacturers, researchers, and industry professionals, focusing on improving the effectiveness and durability of self-adhered membrane systems.



Learning Objectives

1. Identify the main types of PSAs used in Air Barrier Systems
2. Analyze the role of PSAs in air barrier assemblies
3. Evaluate the benefits of PSA systems in building enclosures
4. Understand and apply the key performance evaluation methods for PSAs

Outline

- Components of Self-Adhered Membranes
- What Constitutes a PSA
- Types of Pressure Sensitive Adhesives
- Environmental Impacts on PSAs
- Benefits of PSAs
- Role of PSAs in Building Enclosure
- Performance Evaluation of PSAs
- Conclusions

Components of a Self-Adhered Membrane

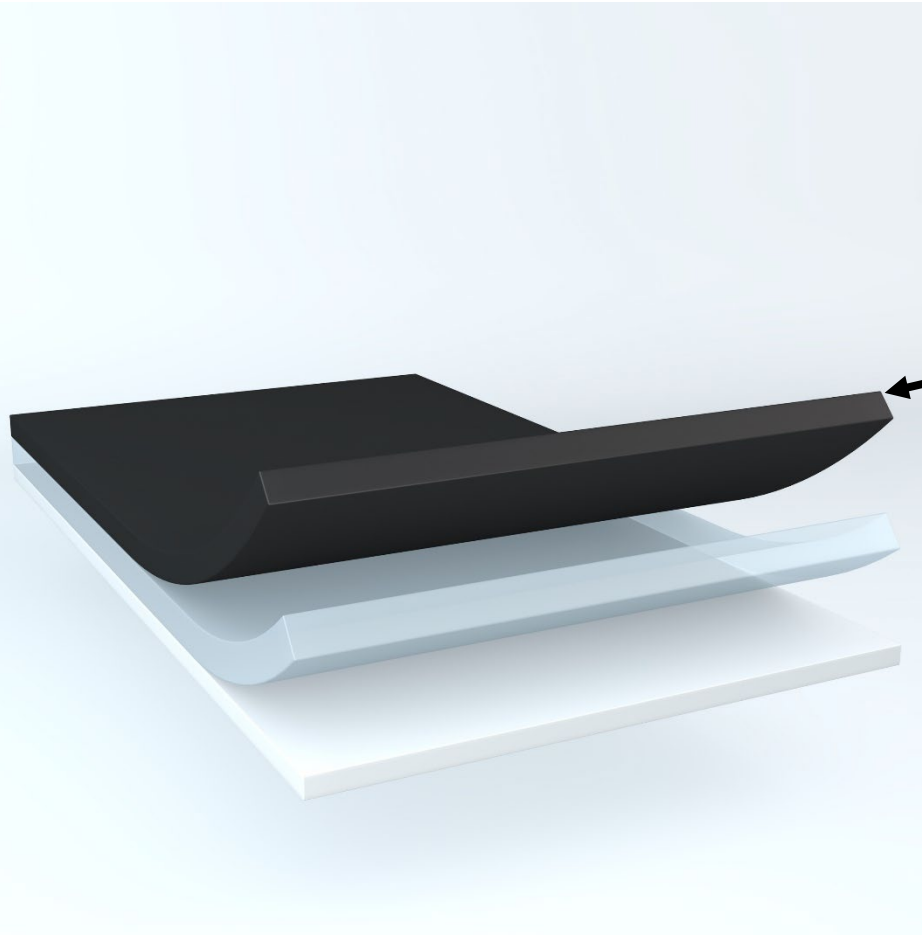

Material (Facer, Backing, Membrane)

- Typically Provides Mechanical Structure
- Any Material of useful interest
 - HDPE
 - TPO
 - Reinforced Bitumen
 - Vapor Permeable Membrane
 - etc. etc. etc.

Components of a Self-Adhered Membrane

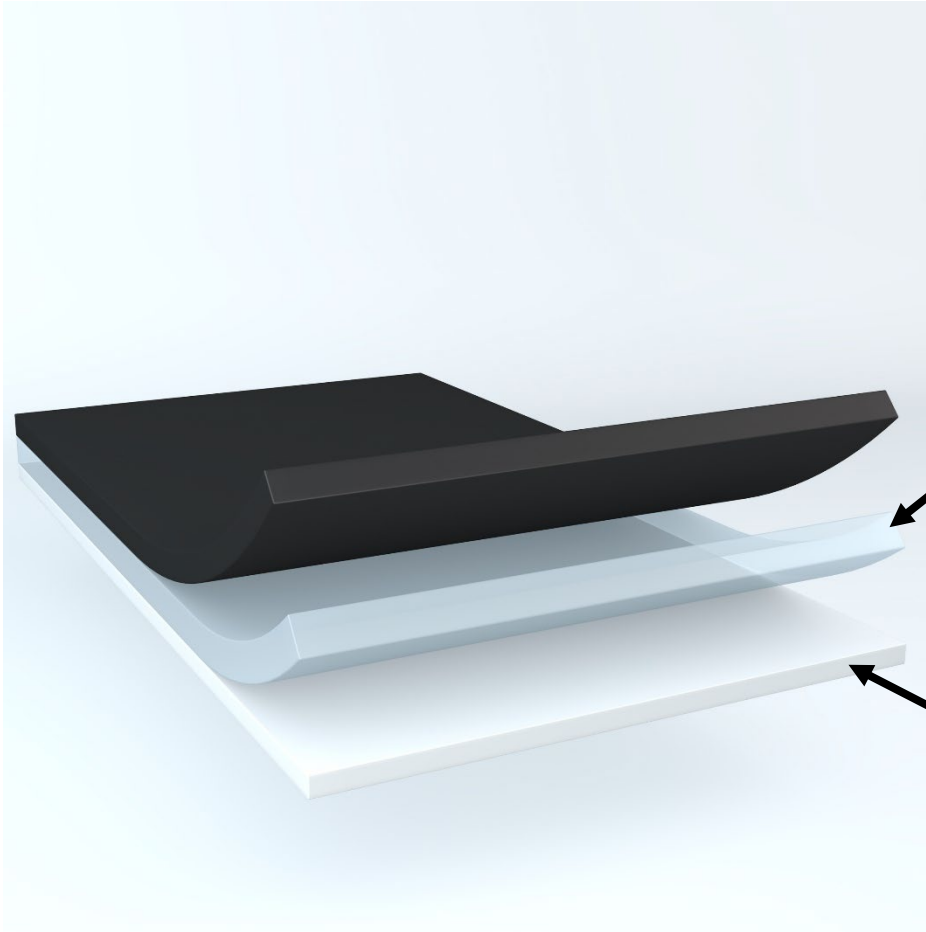

Pressure Sensitive Adhesive(PSA)

- Bonds the material to substrate
- Variety of available solutions
 - modified asphalt
 - acrylic
 - SBS
 - butyl
 - etc. etc. etc.

Liner

- Prevents the adhesive from bonding until desired

**Improved Air
& Water Tightness**



Seals Gaps & Joints

**Faster, Easier
Installation**



Peel & Stick Application

**Long-Term
Durability**



Flexible & Resilient

**Broad
Compatibility**



Bonds to Many Surfaces

Cold & Moisture Resistant

All-Weather Performance



Seaming

Window Flashing

**Energy Efficiency
& Comfort**



Reduces Energy Loss

Why Use Self Adhering Materials

What is a PSA



Combination of Materials

- 1. Base Polymer
(Elastomer / Binder)**
- 2. Tackifiers**
- 3. Plasticizers / Softening Agents**
- 4. Crosslinkers / Curing Agents**
- 5. Additives / Stabilizers**
- 6. Fillers**
- 7. Solvent or Carrier**

Images Courtesy of tesa tape Inc.

What is a PSA

Adhesion

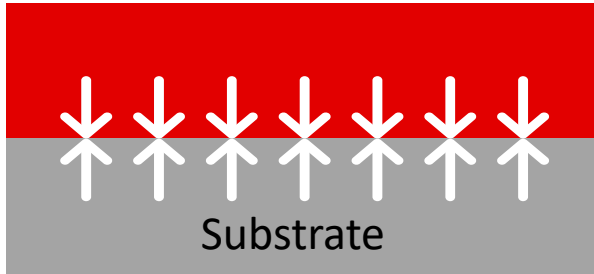

Bonding strength of the adhesive to the substrate

Cohesion

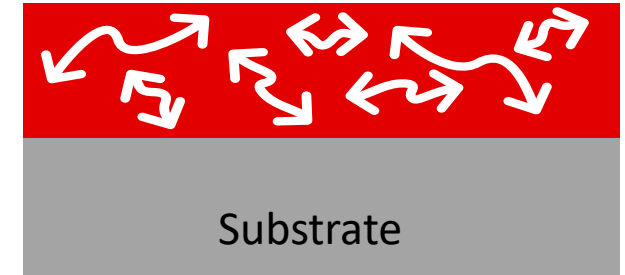

Inner strength of the adhesive, "holding power"

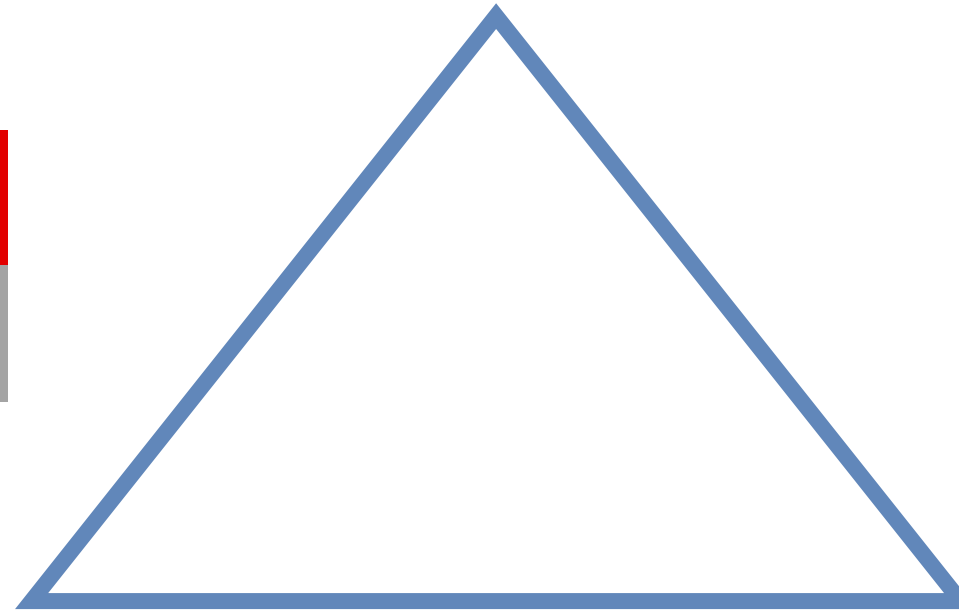

Tack

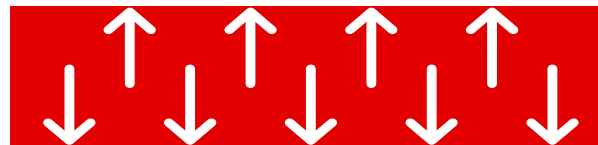

"Contact adhesion" of the adhesive to the substrate

- Permanently Tacky
- Spontaneous Adhering
- Non-curing / setting

What is a PSA

Adhesion

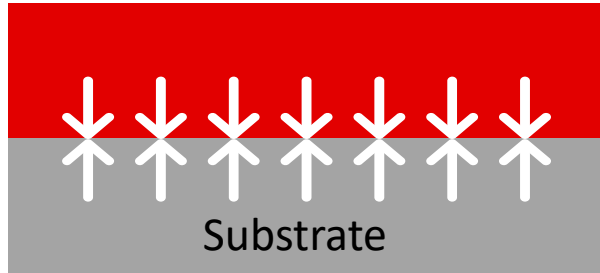

Bonding strength of the adhesive to the substrate

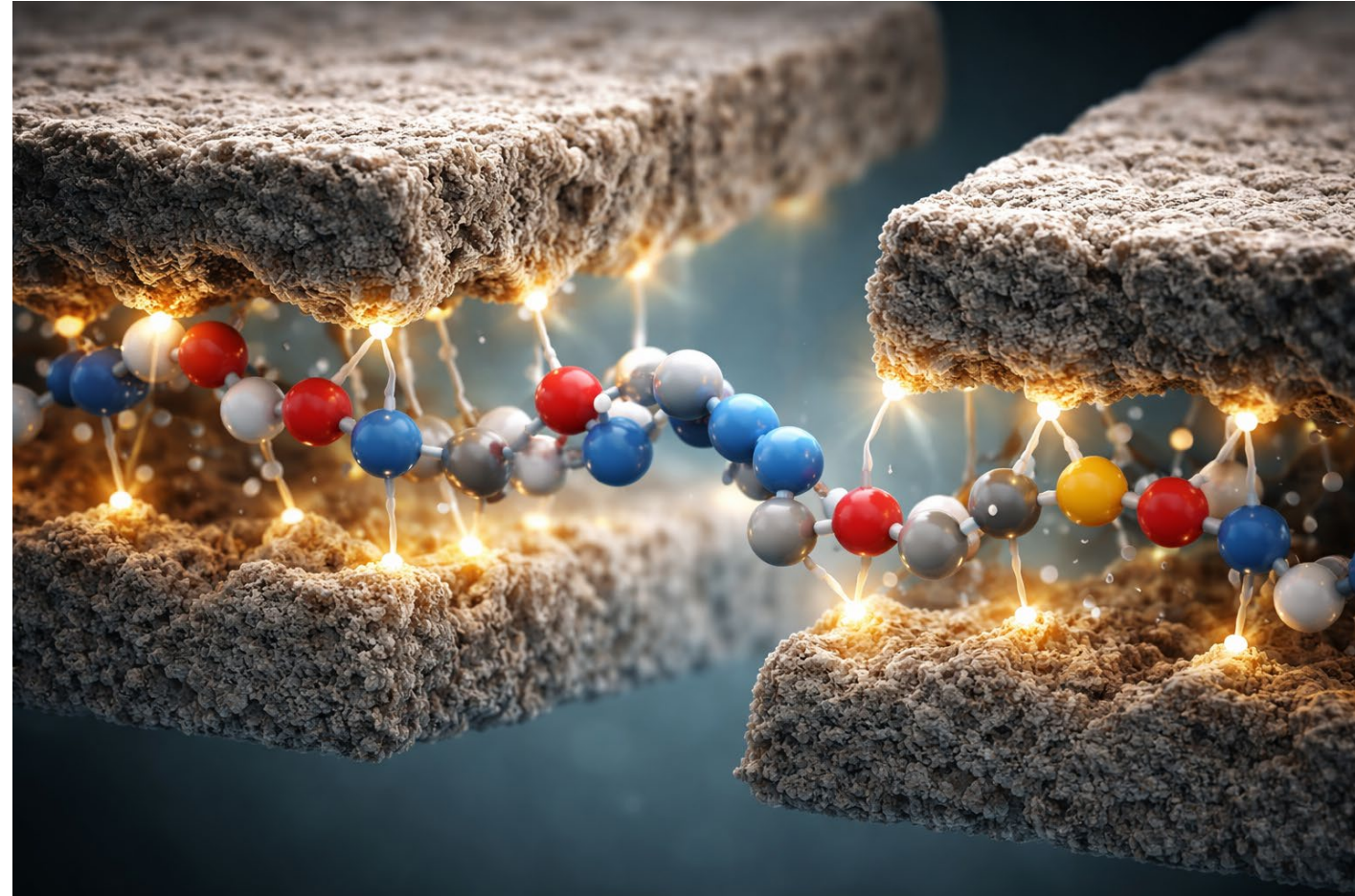

What is a PSA

Adhesion

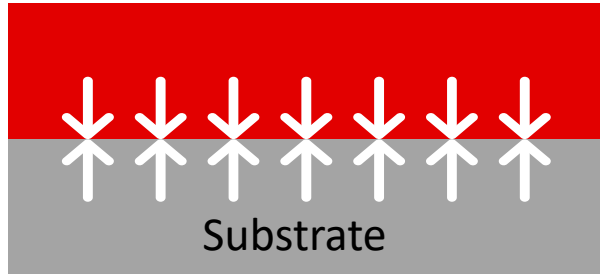

Bonding strength of the adhesive to the substrate

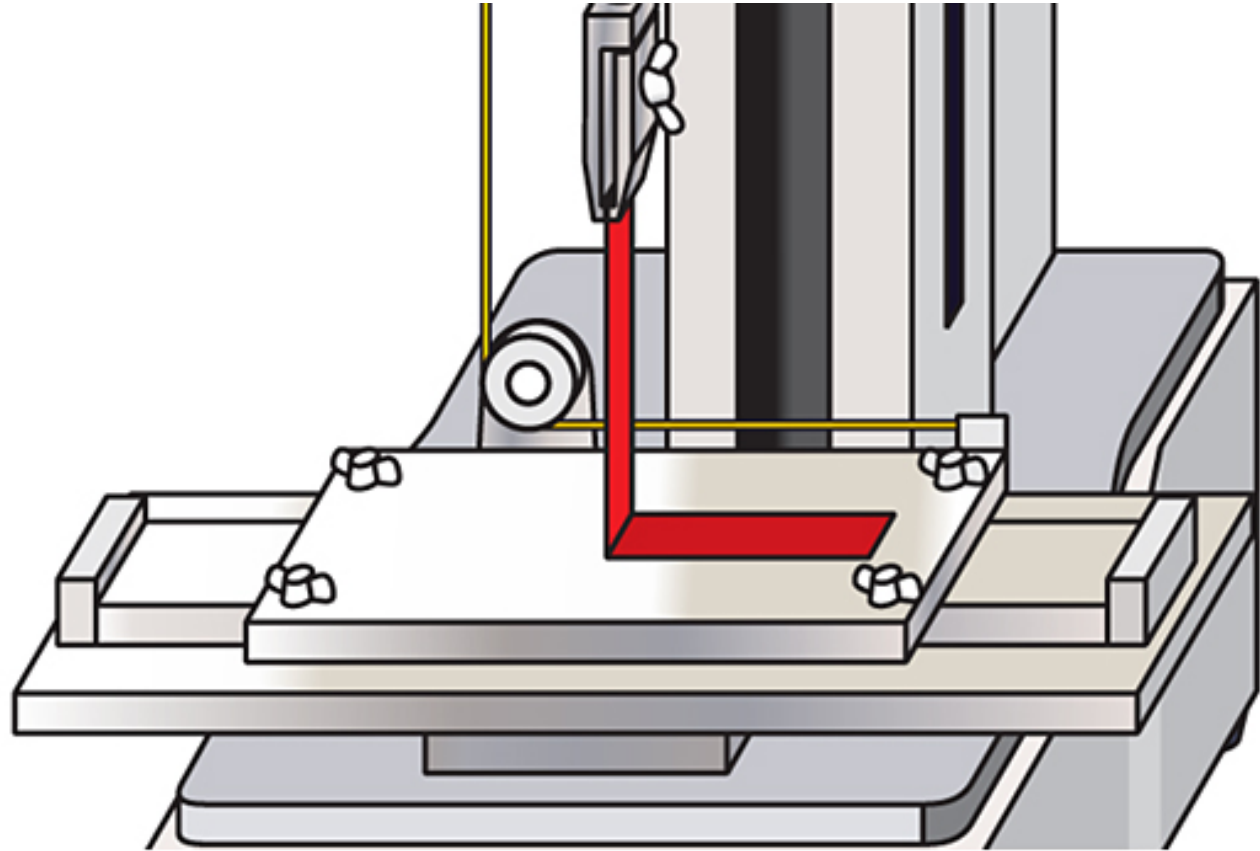

What is a PSA

Tack

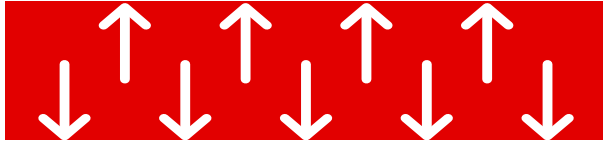

“Contact adhesion” of the adhesive to the substrate



Images Courtesy of tesa tape Inc.

What is a PSA

Tack

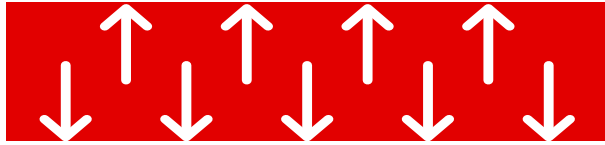

“Contact adhesion” of the adhesive to the substrate



Images Courtesy of tesa tape Inc.

What is a PSA

Cohesion

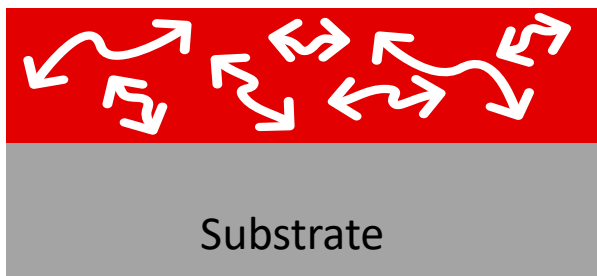

Inner strength of the adhesive, "holding power"

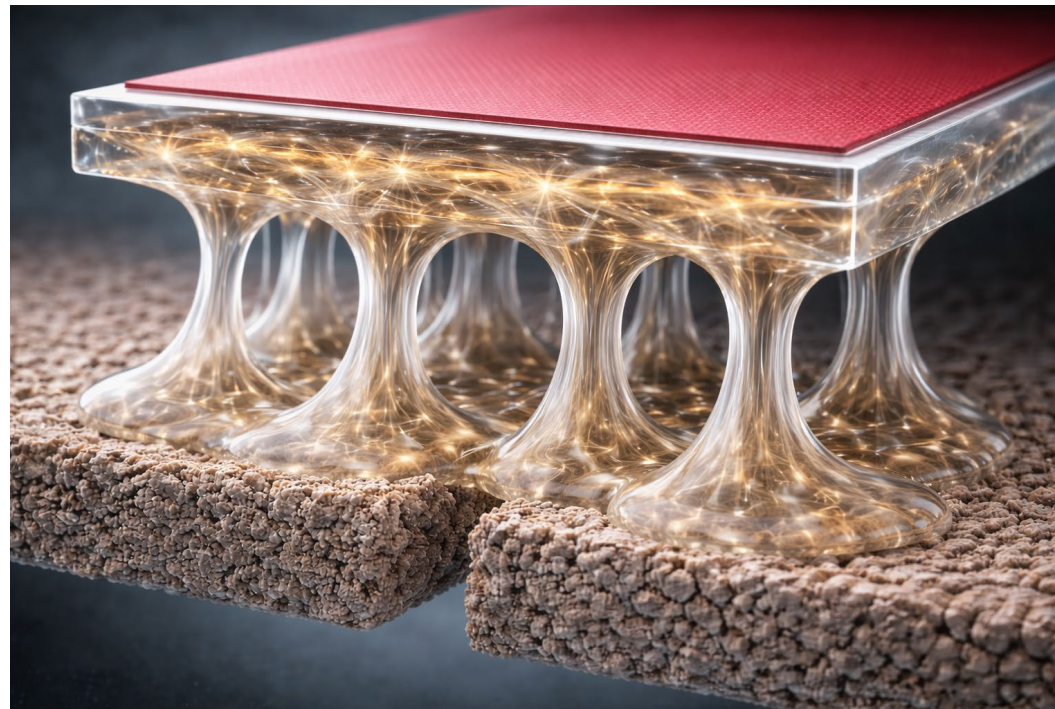

Images Courtesy of tesa tape Inc.

What is a PSA

Cohesion

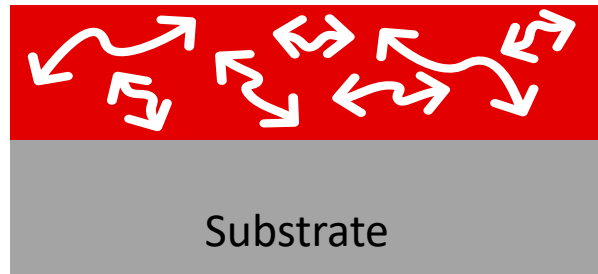

Inner strength of the adhesive, "holding power"

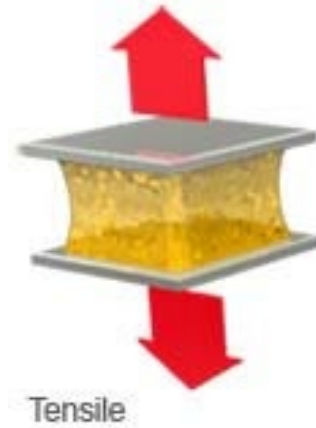

Common Adhesive Testing Methods

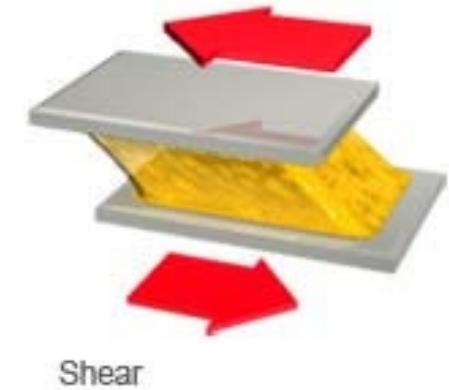

What is a PSA

Adhesion

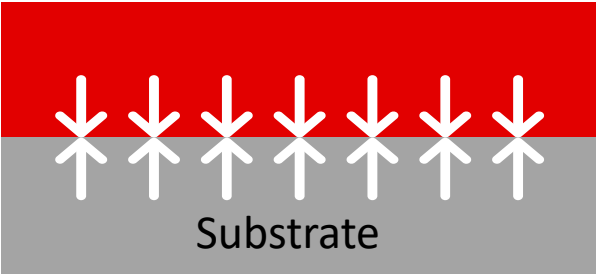

Bonding strength of the adhesive to the substrate

Cohesion

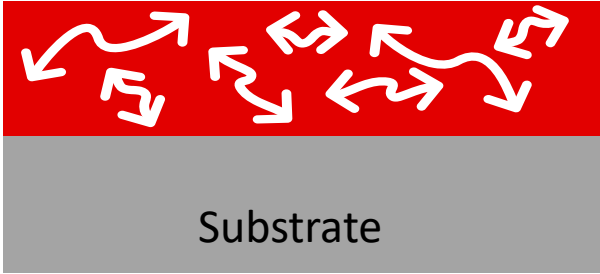

Inner strength of the adhesive, "holding power"

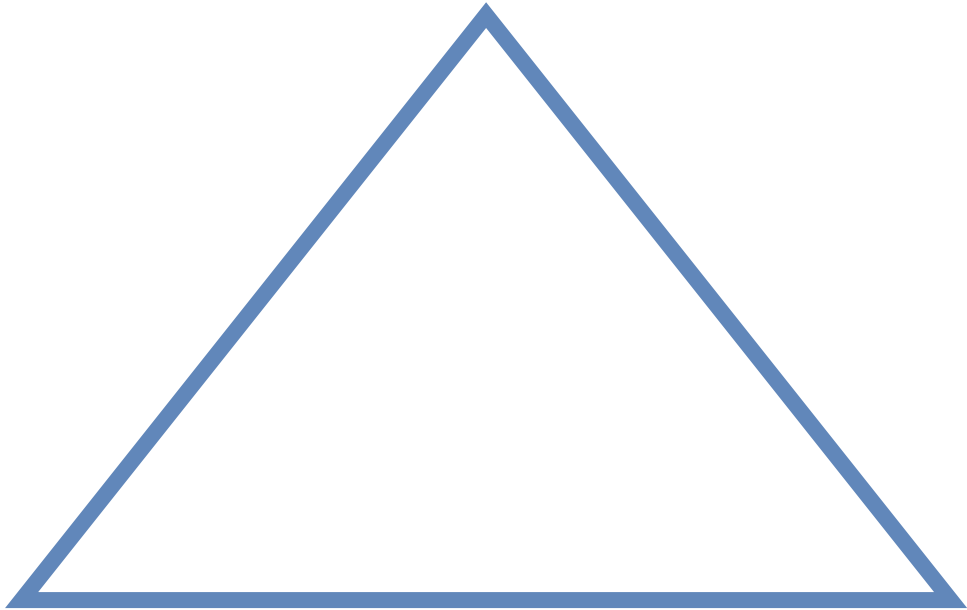

Tack

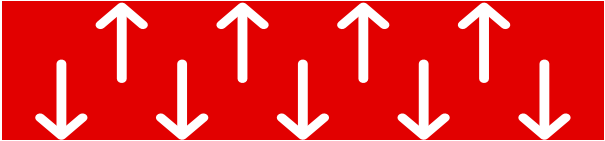

"Contact adhesion" of the adhesive to the substrate

Types of Pressure-Sensitive Adhesives in the Building Enclosure Industry



Asphalt Pressure-Sensitive Adhesives



Benefits

- Strong adhesion to common substrates
- High initial tack
- Effective self-sealing
- Proven water resistance
- Cost-effective
- Substrate-tolerant

Concerns

- Limited high-temperature resistance
- Creep under sustained load
- Cold-weather install limits
- Material compatibility issues
- Odor / VOC considerations
- Sensitive to pressure & dwell time

Rubber-Based Pressure Sensitive Adhesives



Benefits

- Very high initial tack
- Strong adhesion at low temperatures
- Good flexibility and conformability
- Fast bond development
- Effective on rough surfaces
- Holding power

Concerns

- Limited long-term heat resistance
- Higher creep under sustained load
- Reduced UV and weathering resistance
- Faster aging vs. acrylic PSAs
- Potential compatibility issues
- Typically lower long-term durability

Acrylic-Based Pressure Sensitive Adhesives

Benefits

- Excellent long-term durability
- Superior UV and weathering resistance
- Strong high-temperature performance
- Lower creep under sustained load
- Broad material compatibility
- Low odor / low-VOC options

Concerns

- Lower initial tack than rubber PSAs
- Slower bond build with dwell time
- Reduced low-temperature adhesion
- Higher material cost
- Greater surface prep sensitivity
- Less forgiving on rough substrates



Impacts on PSAs

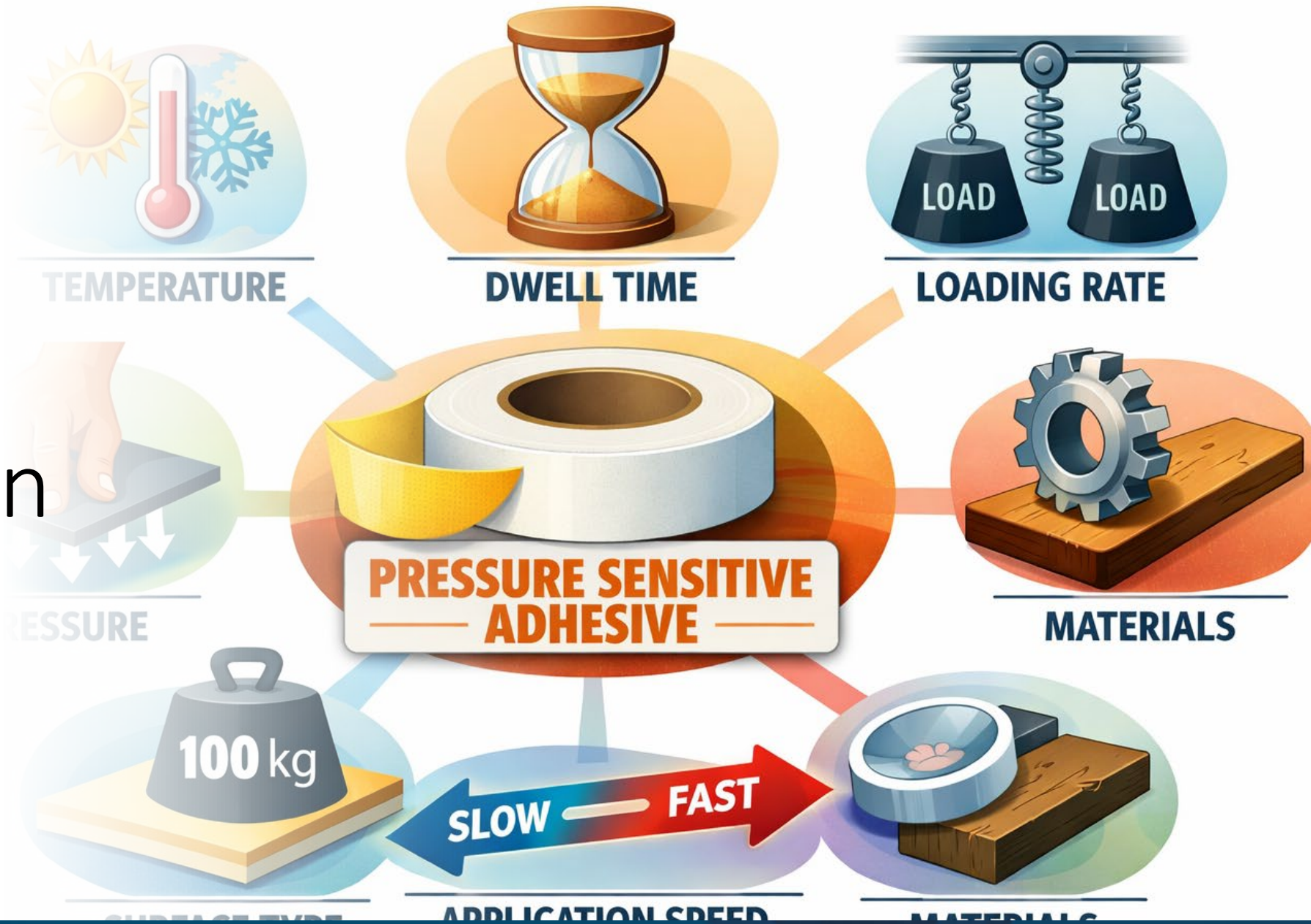

Application Pressure

Proper method

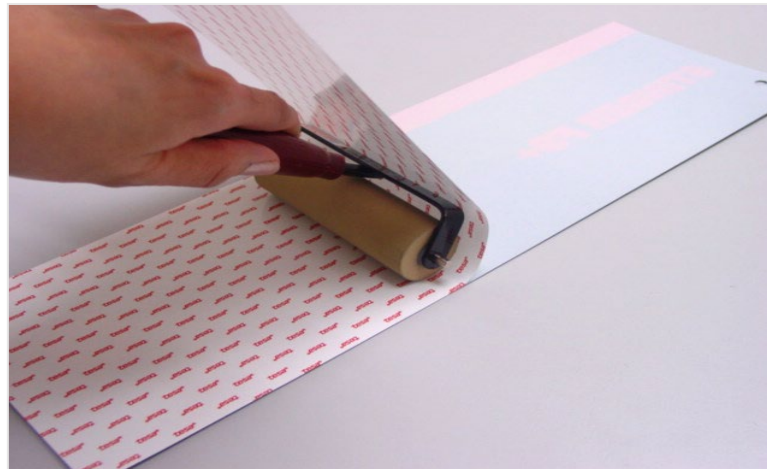
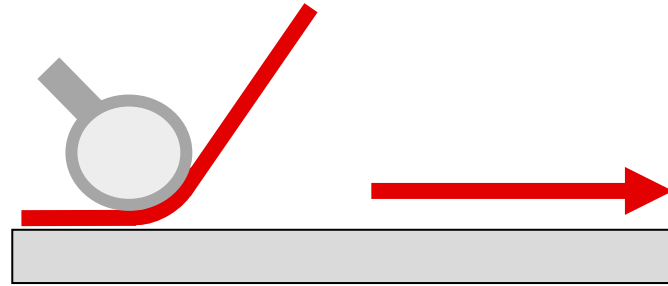

Often seen

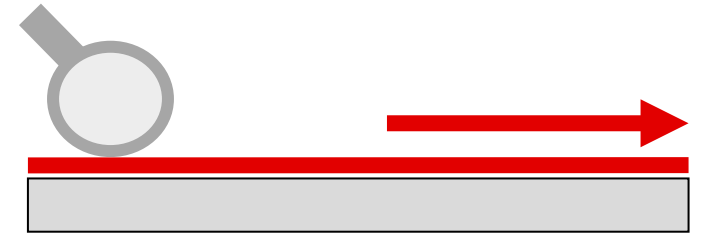

Images Courtesy of tesa tape Inc.

Application Pressure

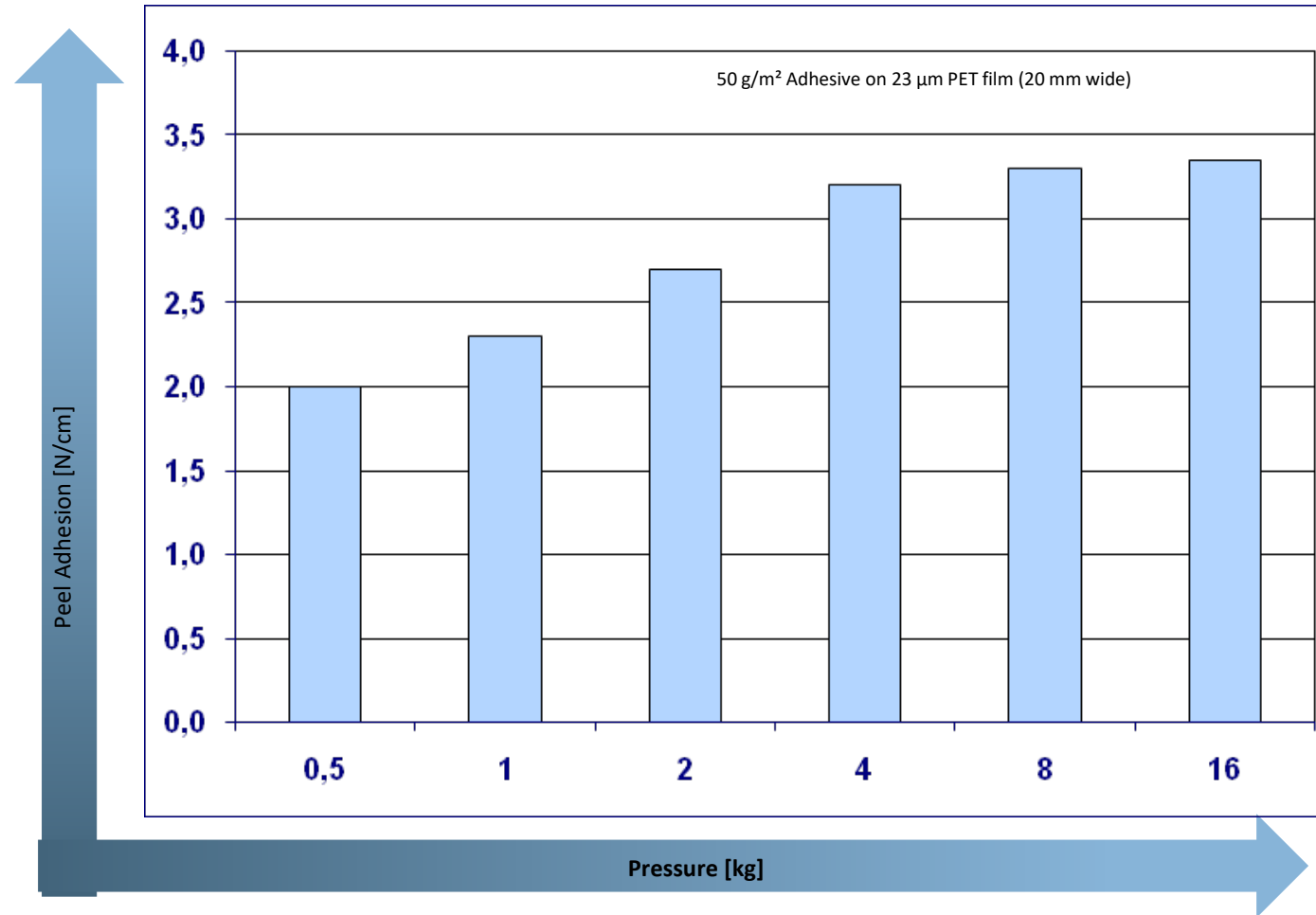

Dwell Time

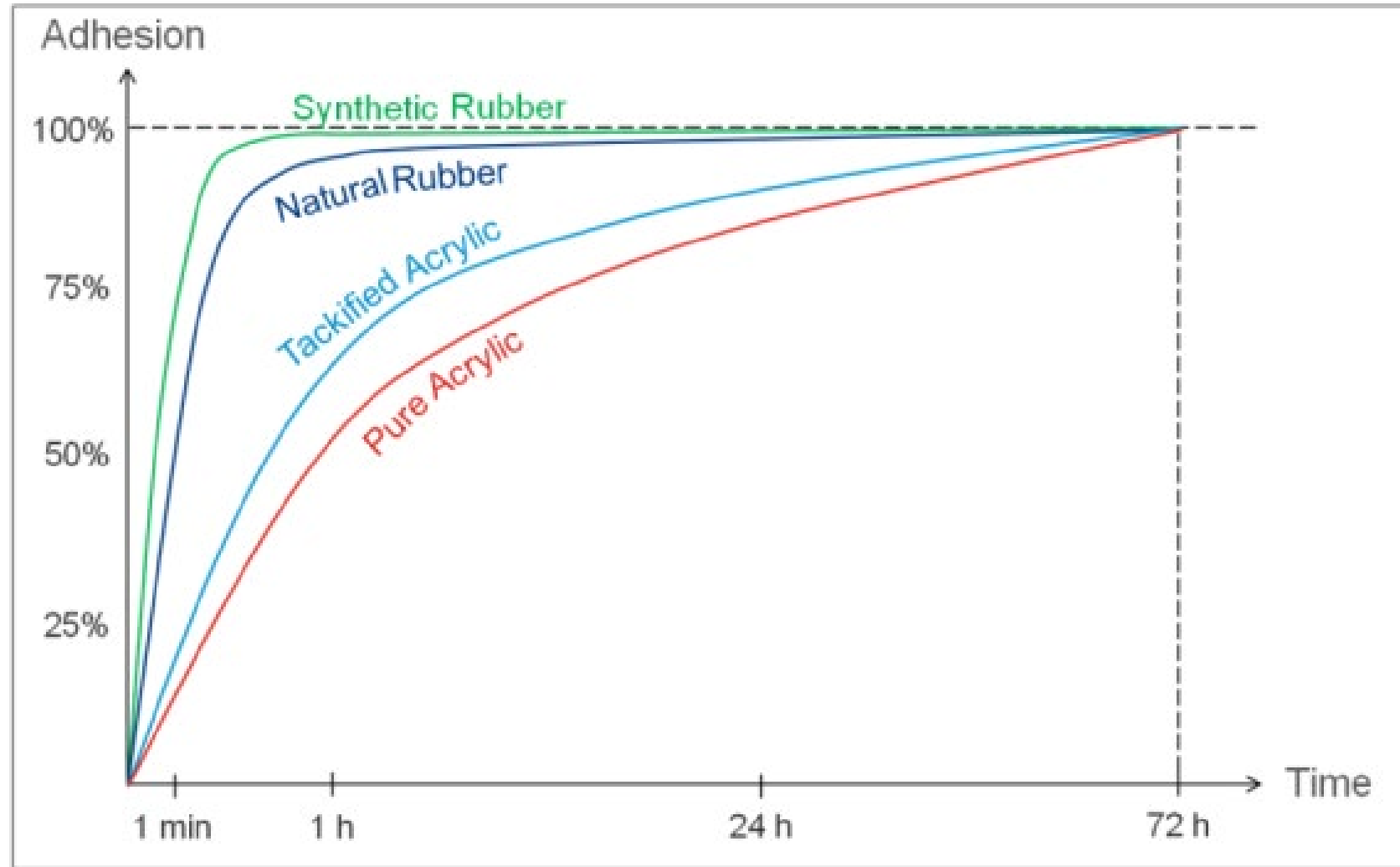

Images Courtesy of tesa tape Inc.

Dwell Time

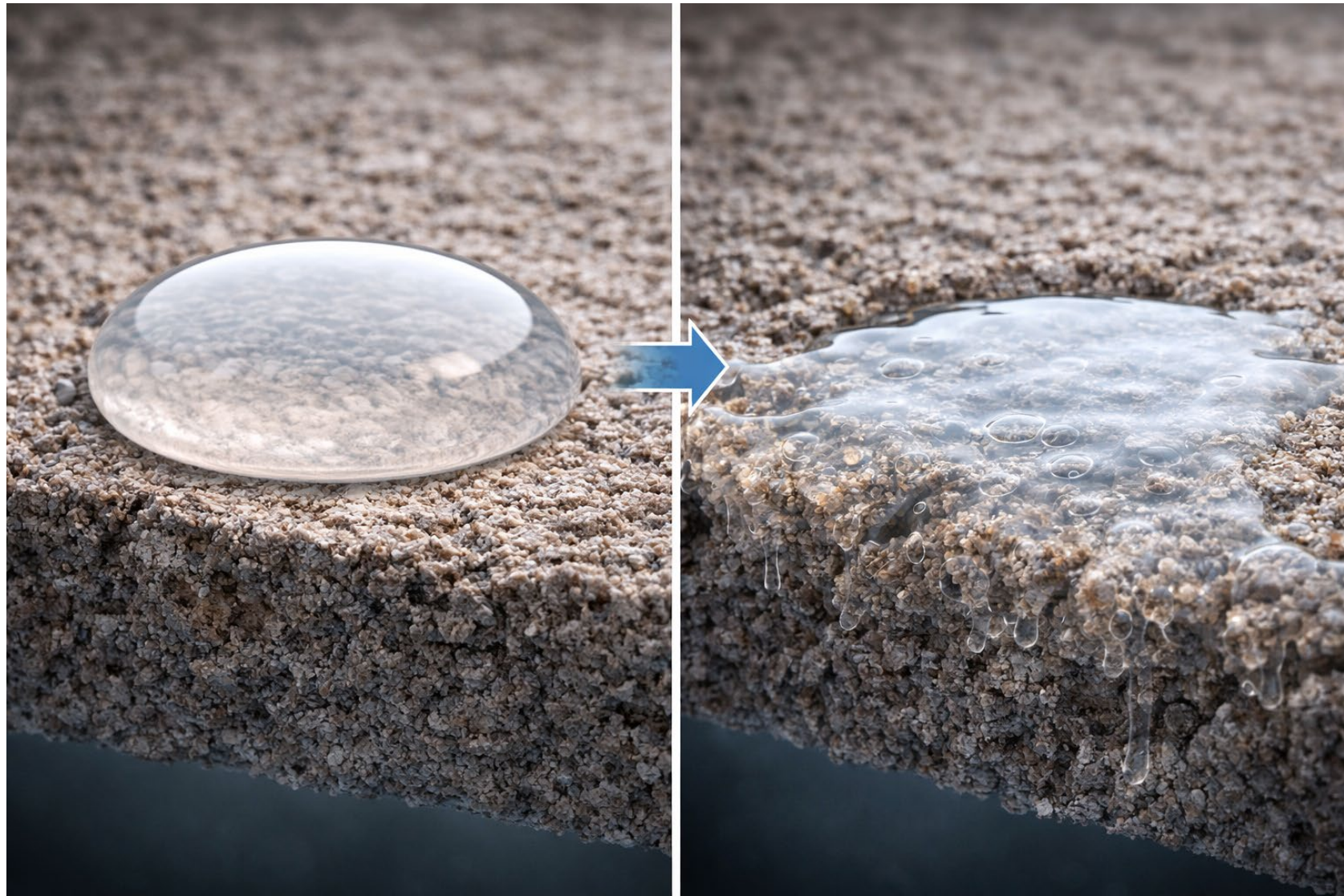

Images Courtesy of tesa tape Inc.

Temperature Exposure

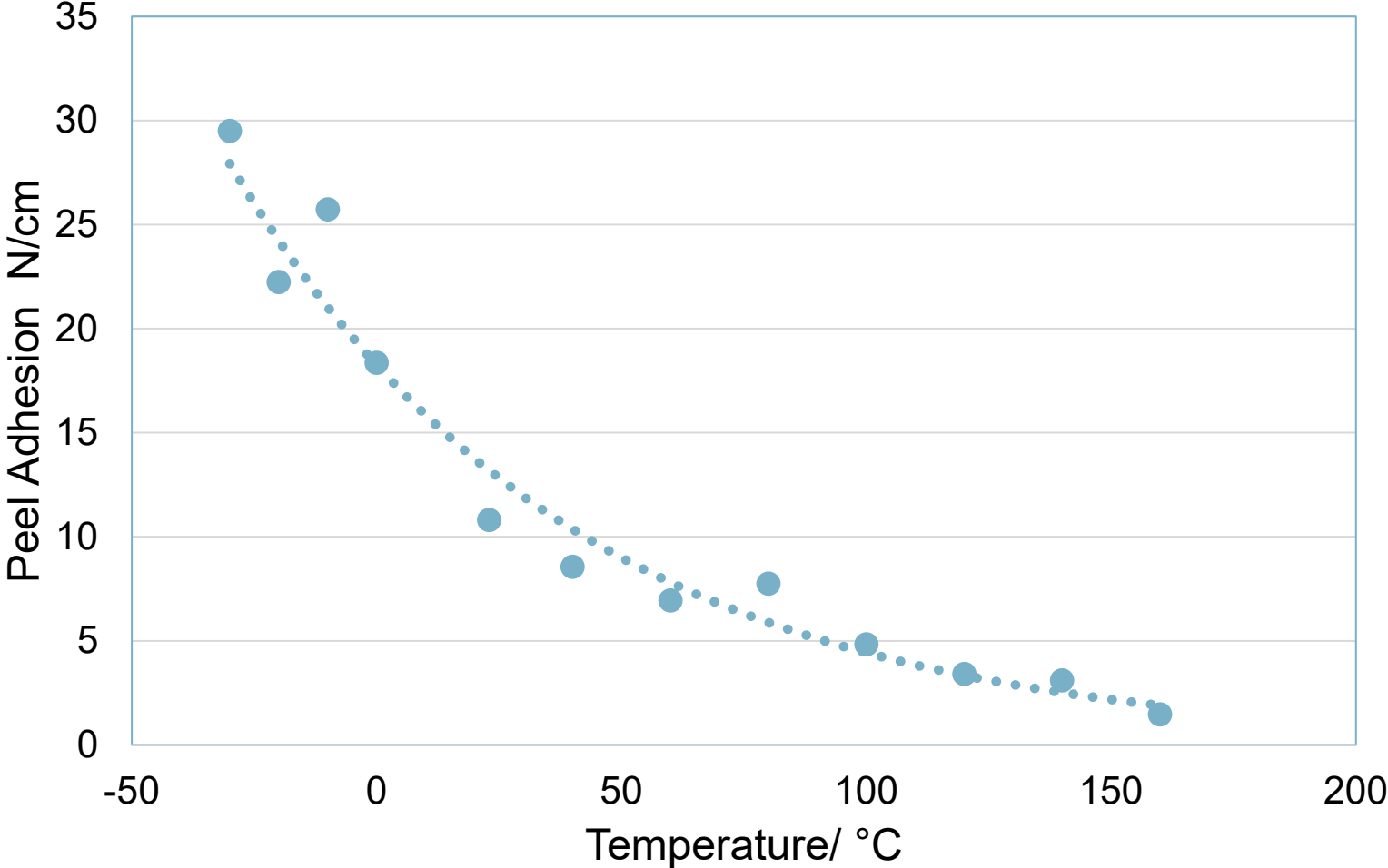

Images Courtesy of tesa tape Inc.

Temperature Exposure

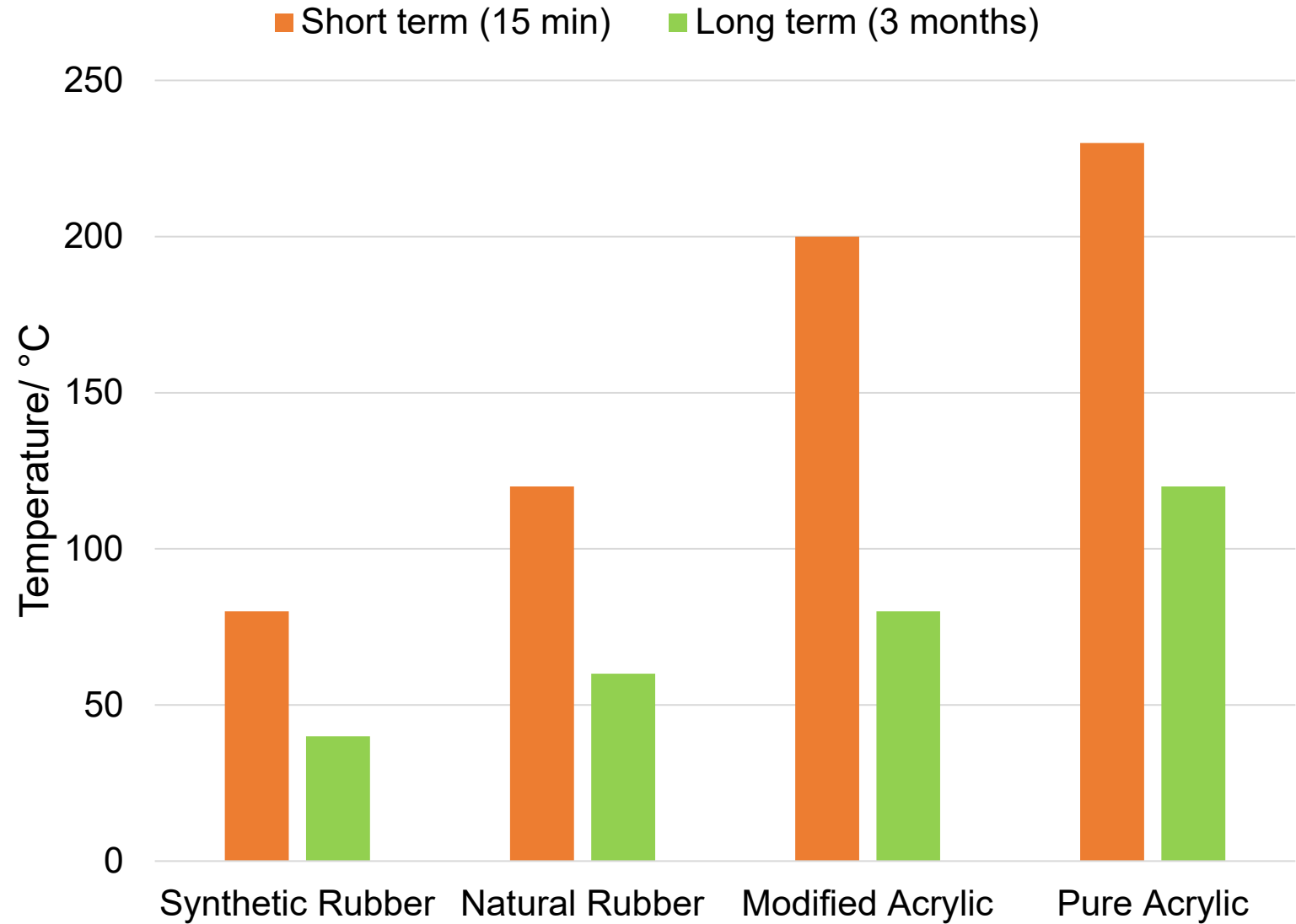
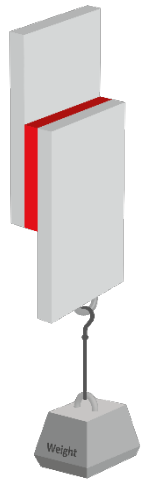

Loading Rate

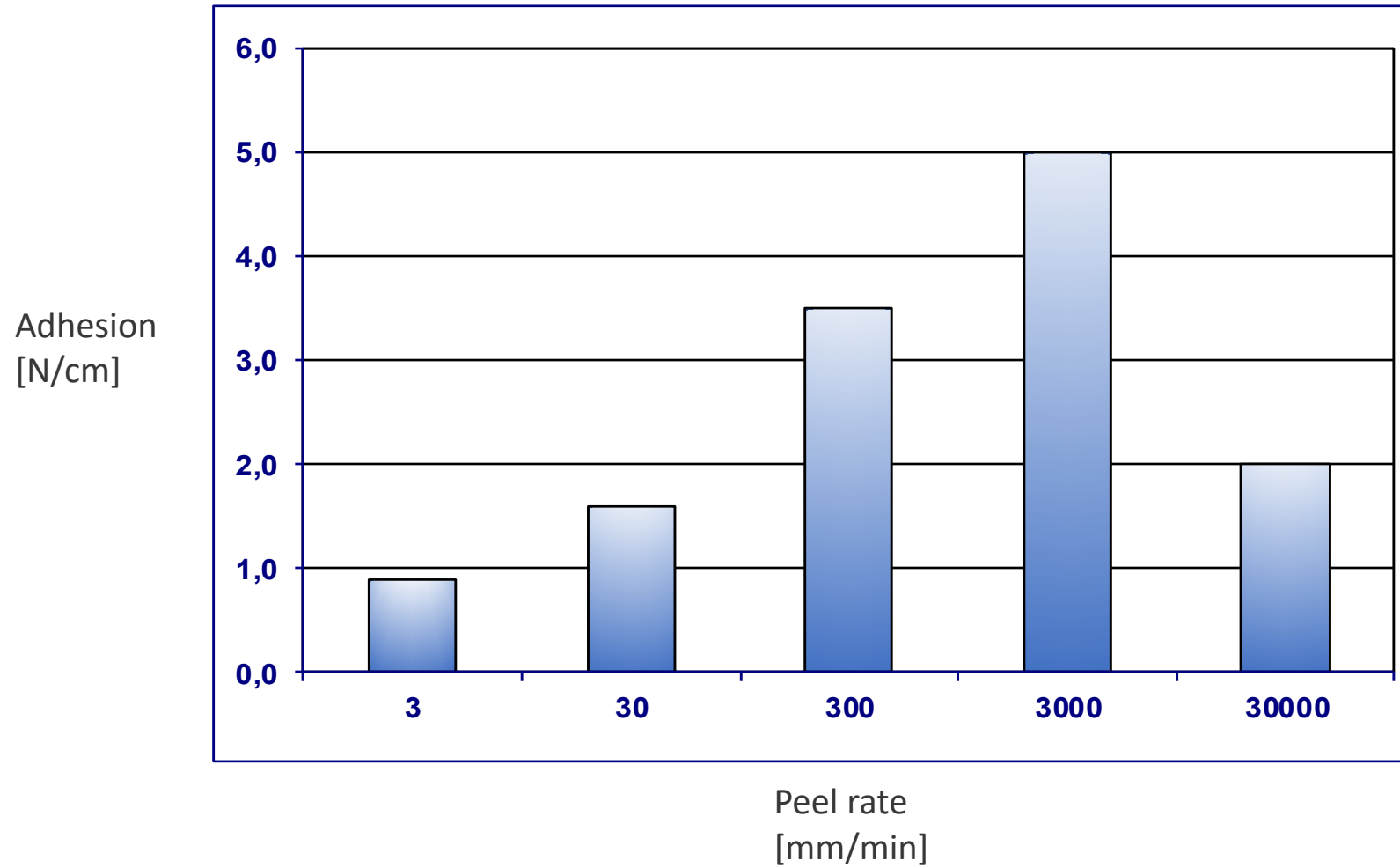

IT DEPENDS



Combination of Materials

1. **Base Polymer**
(Elastomer / Binder)
2. **Tackifiers**
3. **Plasticizers / Softening Agents**
4. **Crosslinkers / Curing Agents**
5. **Additives / Stabilizers**
6. **Fillers**
7. **Solvent or Carrier**

Images Courtesy of tesa tape Inc.

Evaluation of Self-Adhesive Membranes

- Test Methods used in AEC Standards

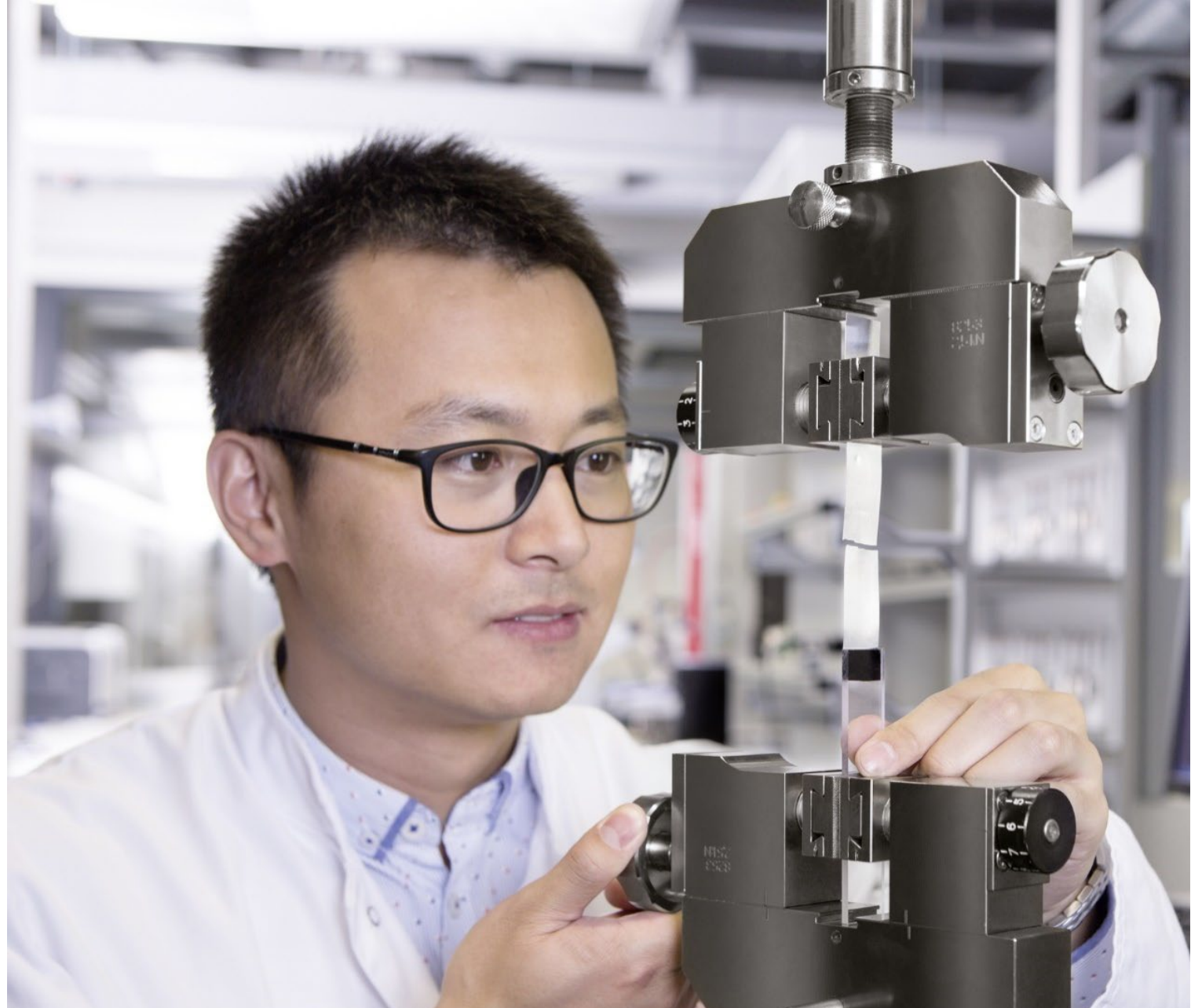



ASTM D903

- Peeling or Stripping Strength of Adhesive Bonds

ASTM D903

- **Benefits**
- Simple Methodology
- Broad Applicability



Concerns

- Single Angle of Peel
- Only Evaluates Peel Force
- Thick Materials
- Comparability of Products
- Elongation of Materials

Images Courtesy of tesa tape Inc.

Elongation of Facer Material During Peel

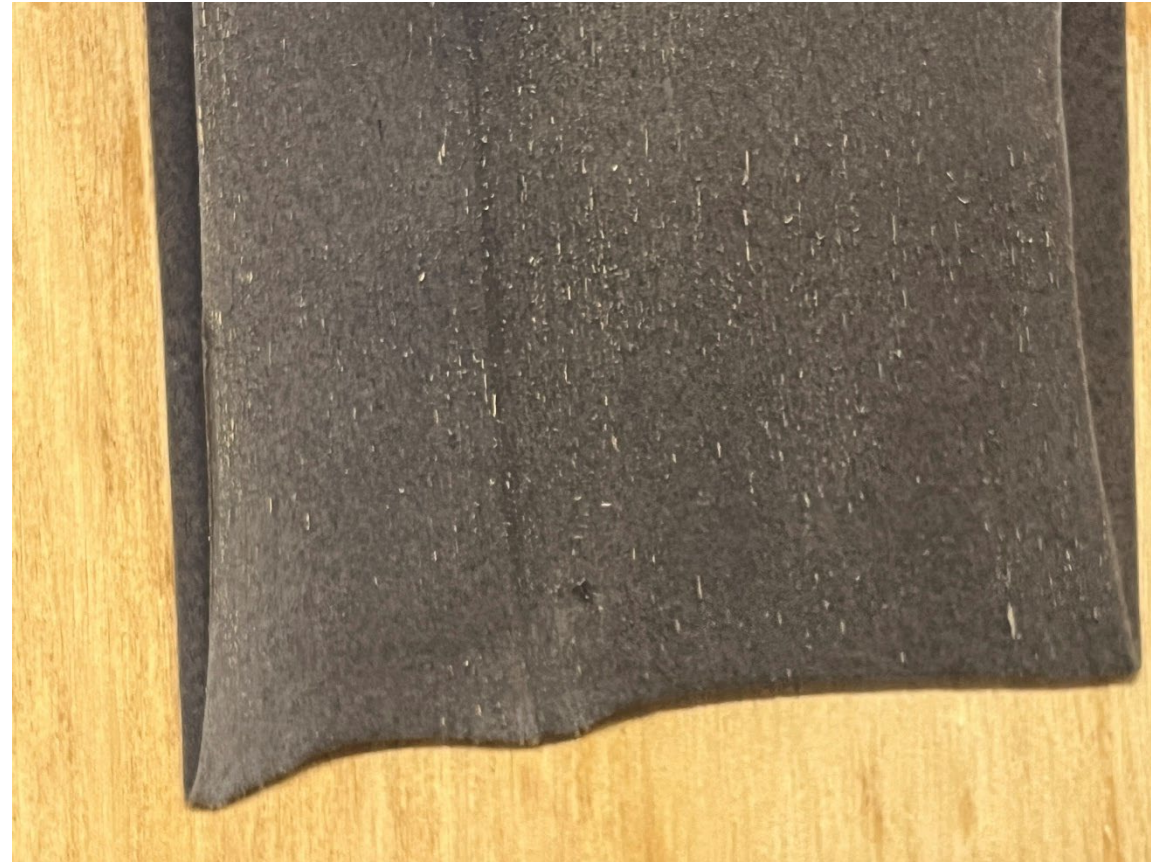

Images Courtesy of tesa tape Inc.

ASTM D3330

- Standard Test Method for Peel Adhesion of Pressure-Sensitive Tape

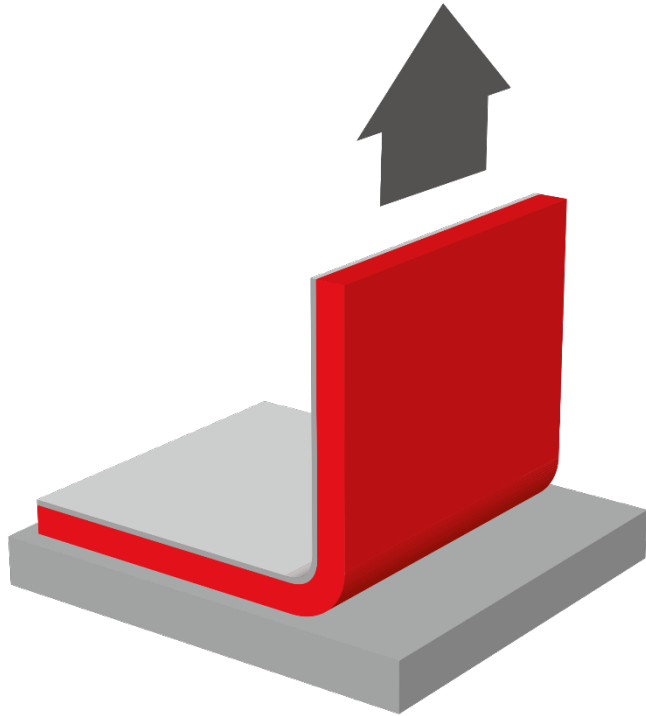

Images Courtesy of tesa tape Inc.

ASTM D3330

Benefits

- Simple Methodology
- Broad Applicability
- Multiple Angles
- Specific Methodology for Adhesion to Self

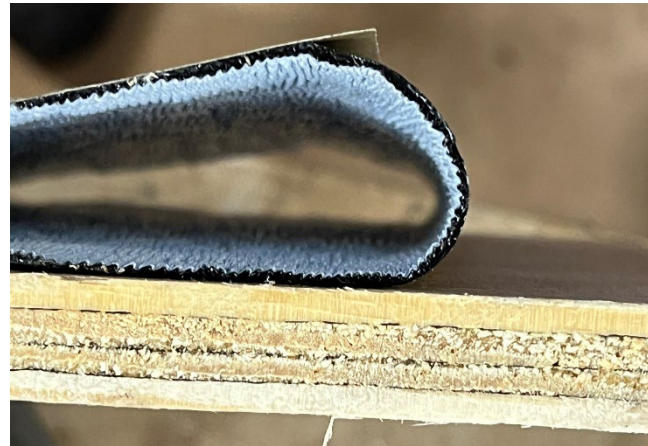

Concerns

- Elongation of Backing
- Only Evaluates Peel Force
- Thick Materials

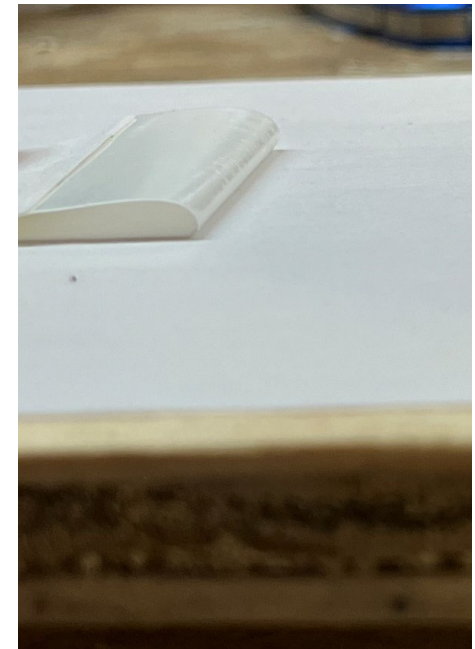



ASTM C794

- Adhesion-in-Peel of Elastomeric Joint Sealants

ASTM C794

Benefits

- Broad Applicability
- Specification of Failure Mode Interpretation



Concerns

- Test for Sealants
- No information on how to prepare samples for non-fluid materials.
- Not Applicable to Self-Adhered Membranes

ASTM D1876

- Standard Test Method for Peel Resistance of Adhesives (T-Peel)

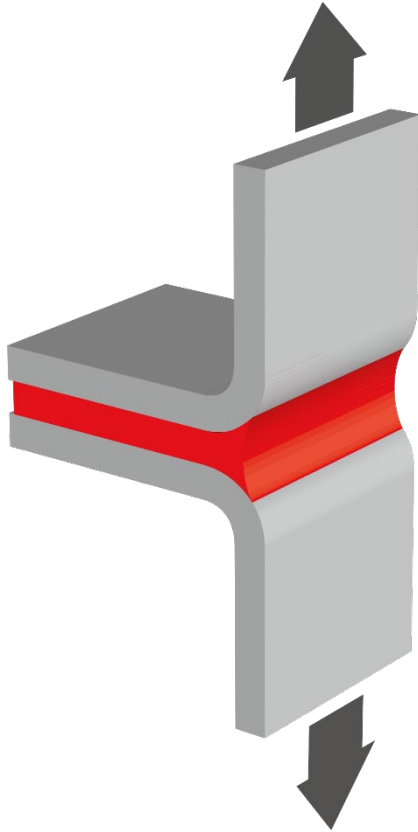

- ASTM D1876

Benefits

- Broad Applicability
- Evaluation of a wide variety of materials



Concerns

- Sample Preparation
- Target Evaluation

ASTM D4541 / ASTM D7234 / ABAA T0002

- Pull-off Strength of Coatings

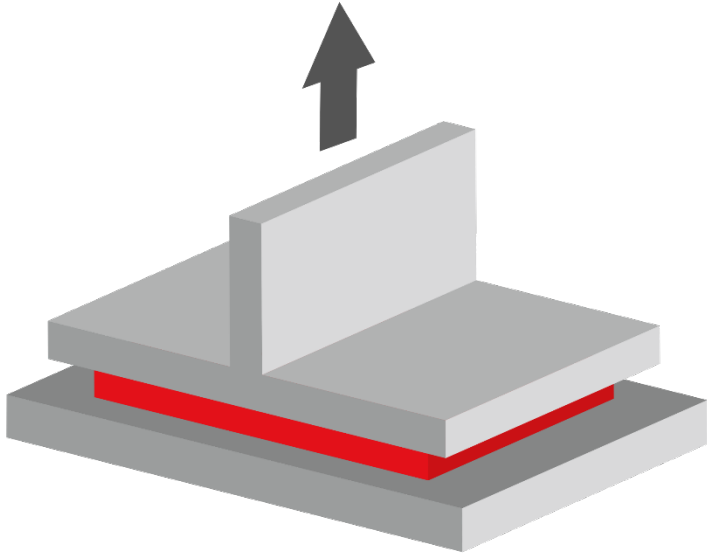

Pull off Strength

Benefits

- Broad Applicability
- Ease of Field Evaluation
- Evaluates Strength Over an Area

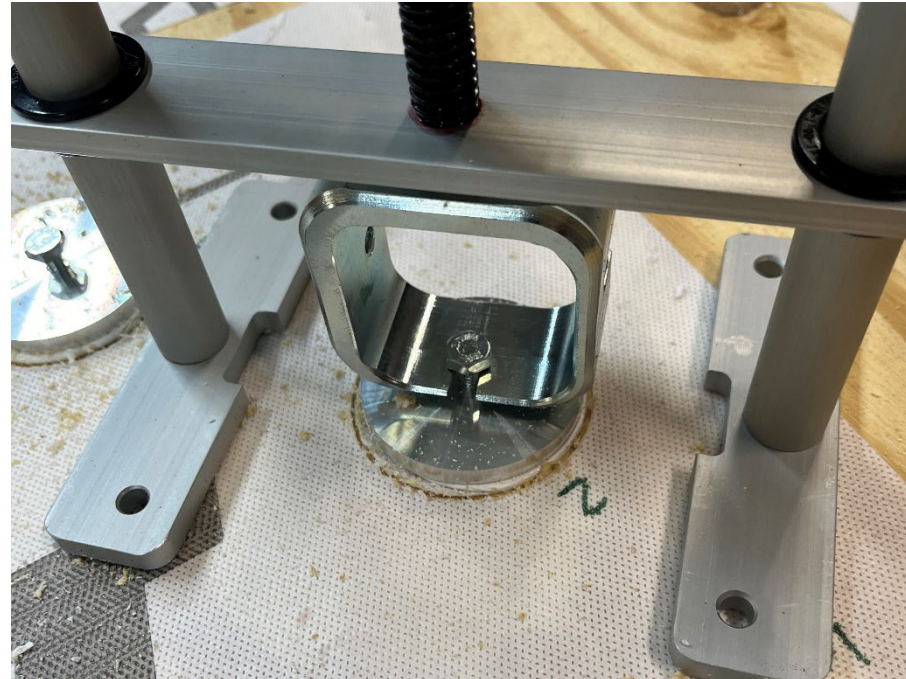
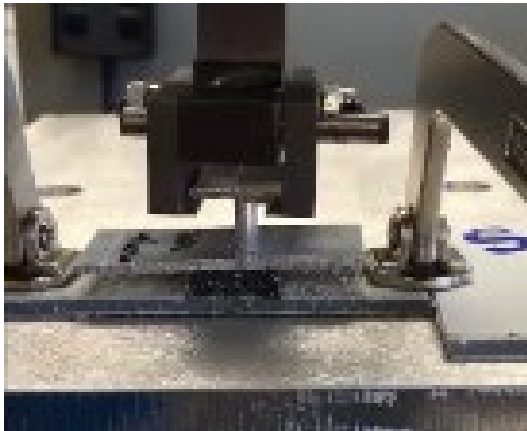

Concerns

- Load Rates
- Sampling (cutting)
- Evaluation of Composite Materials

Other Test Methods

ASTM D7281

- Evaluation of Seams

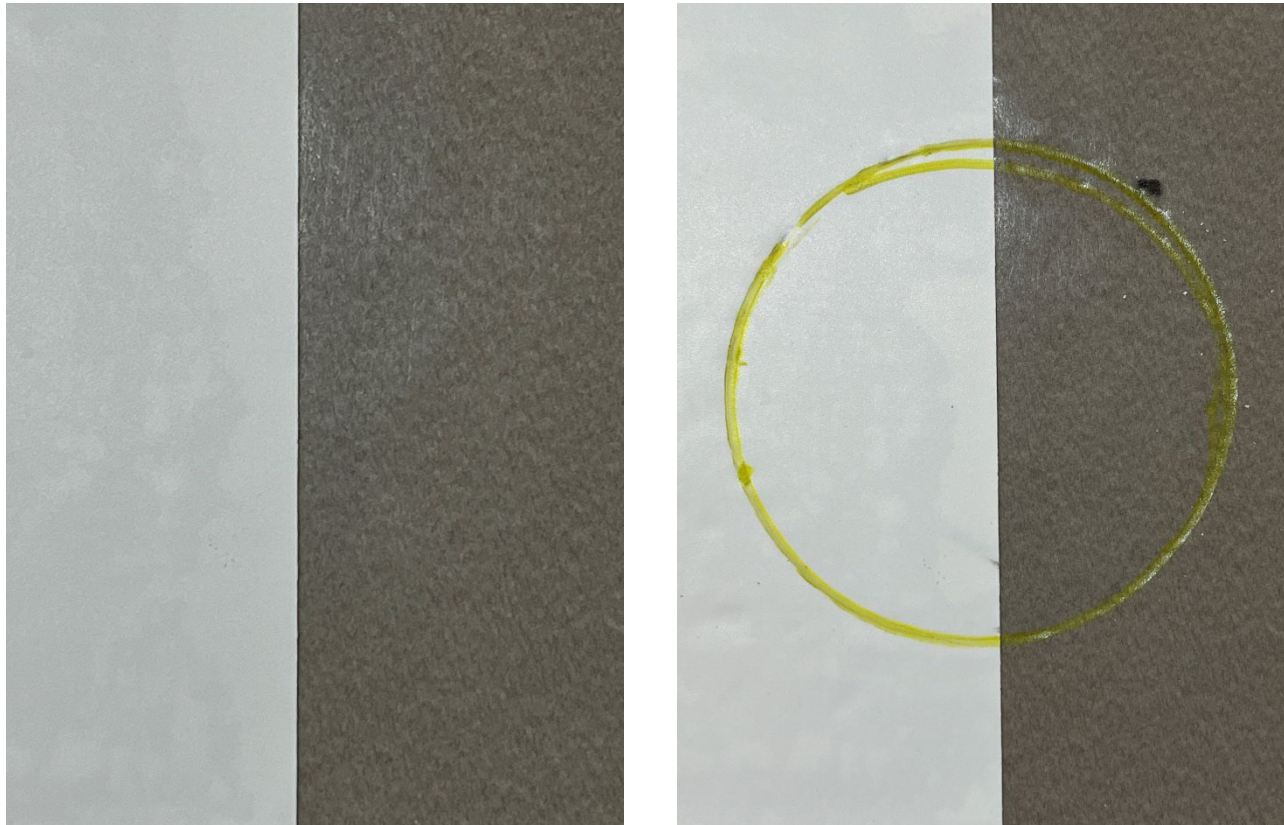

ASTM D5385 Modified

- Movement of Water Between Membrane

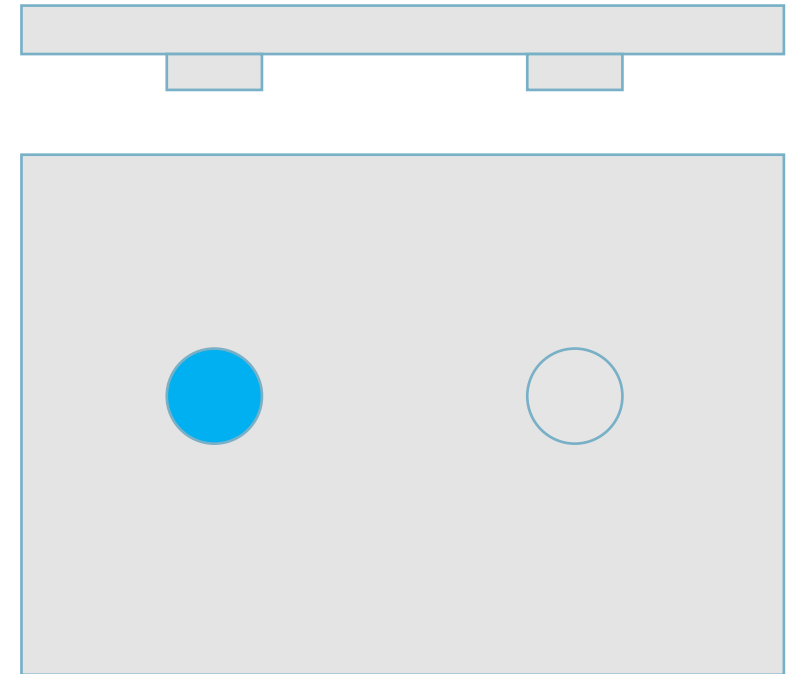

Images Courtesy of tesa tape Inc.

Current Testing Summary

- **Focus on Peel Adhesion**
- **Require Modified Sample Preparation**
- **Focus on Coatings and Sealants**
- **Lack broad temperature and loading range**
- **Lack Static Loading**

Membranes in Application



Membranes in Application



Images Courtesy of tesa tape Inc.

Membranes in Application

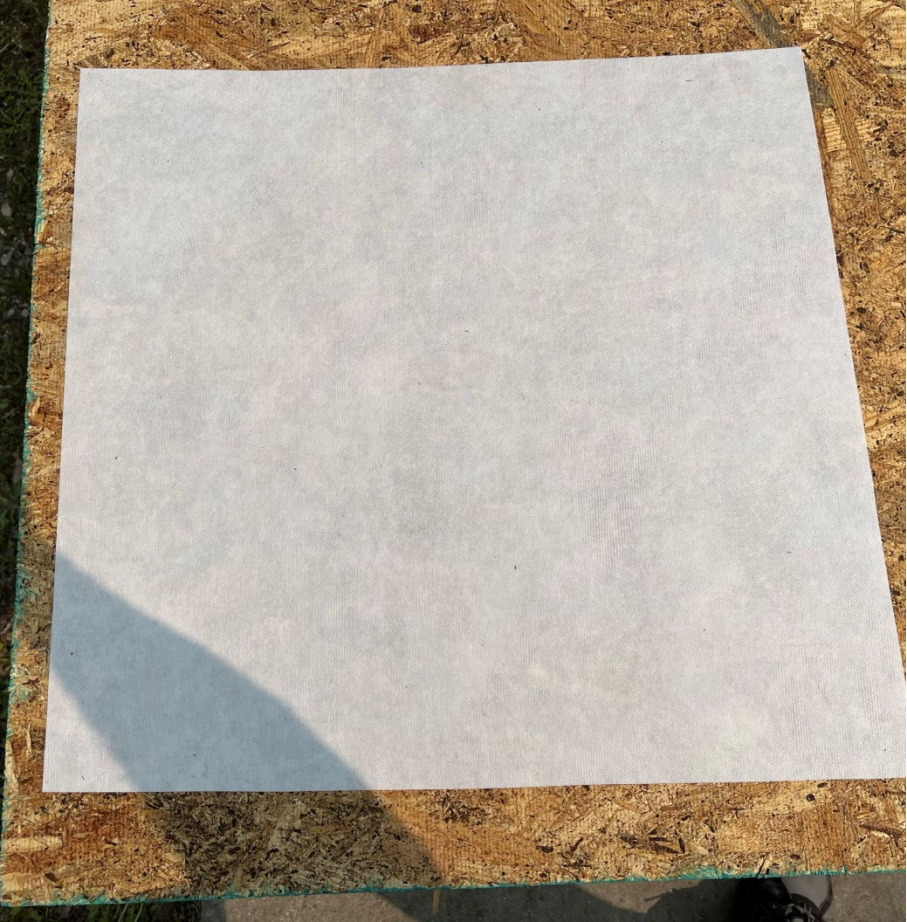

Images Courtesy of tesa tape Inc.



No Peel

Images Courtesy of tesa tape Inc.

Edges of Membranes

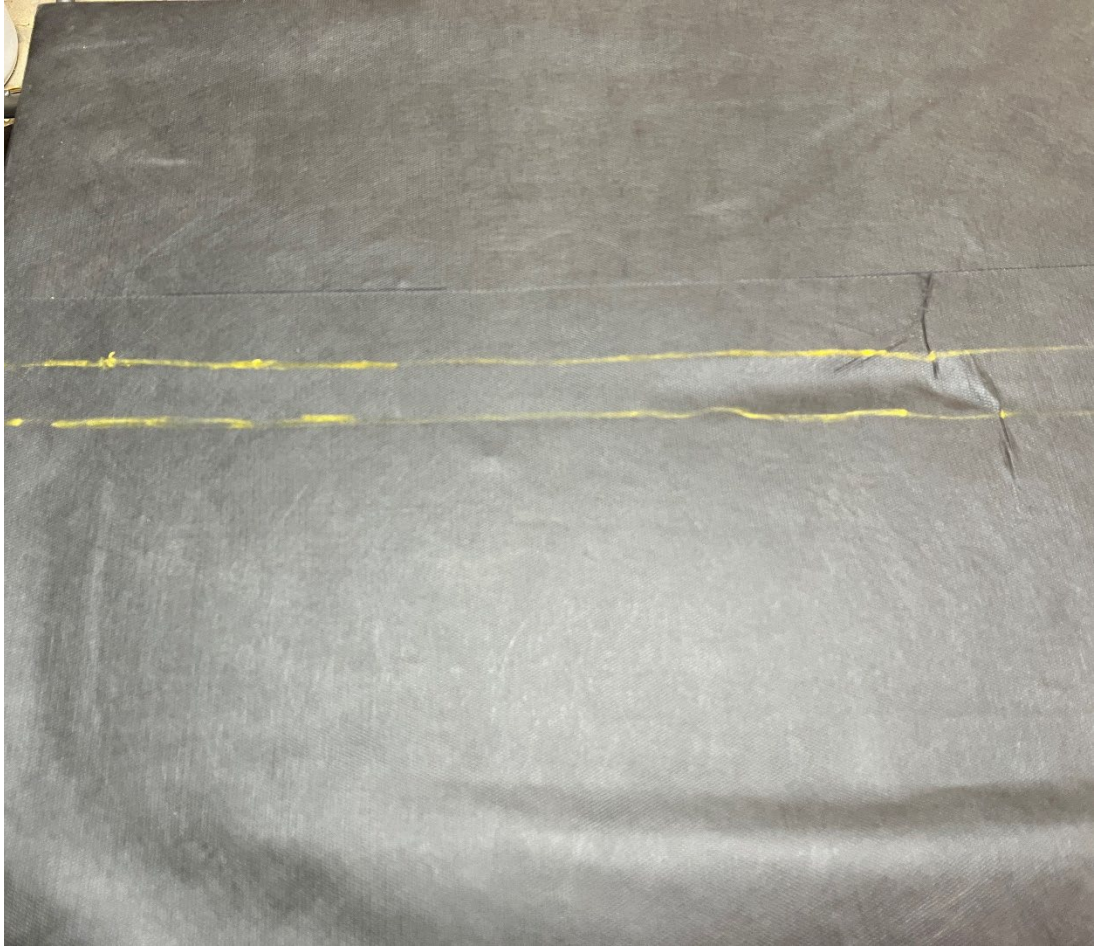

Images Courtesy of tesa tape Inc.

CONCLUSION

- Design of Self-Adhered Membranes Requires More Than Peel
- Resistance for Pressure Sensitive Adhesives is Dependent on Many Factors
- Comparison Between Products Requires careful understanding of the methods of evaluation.

ANY QUESTIONS?

SELF-ADHERED MEMBRANES • PRESSURE SENSITIVE TAPES



Let's Connect :

Cody Shelner, PE

Building Enclosure Technical Manager

Mobile: (616)560-3174

E-Mail : Cody.Shelner@siplast.com

LinkedIn:

<https://www.linkedin.com/in/cody-shelner/>

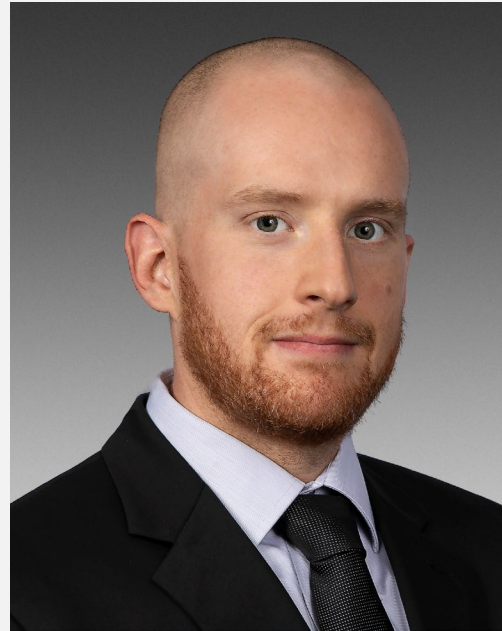

Cody Shelner, P.E.